

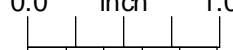

# OUTLINE

UNLESS OTHERWISE SPECIFIED DIMENSIONS ARE IN INCHES AND INCLUDE CHEMICALLY APPLIED OR PLATED FINISHES		THE CONTENTS OF THIS DOCUMENT ARE PROPRIETARY TO NAVITAR, ITS USE IS AUTHORIZED ONLY FOR RESPONDING TO REQUEST FOR QUOTATION OR PERFORMANCE OF WORK FOR NAVITAR		 ROCHESTER, NEW YORK	
SCALE:	1:2	0.0    inch    1.0  0.0    mm    25.0 		582MCL047 12mm f2.5 LENS FOR SHARP PH50	
WEIGHT:	4.3lbm			SIZE	1-17018
DR:	DJM	A	SHEET 1 OF 1	B	
CH:	R. E. PODLENA				
PROJECT #:	E2007				
DATE DR:	7/25/2005	DO NOT SCALE DRAWING			

