

REVISION HISTORY				
REV	DESCRIPTION	DATE	APPROVED	CH BY
A	RELEASED	7/29/2005	BE	REP

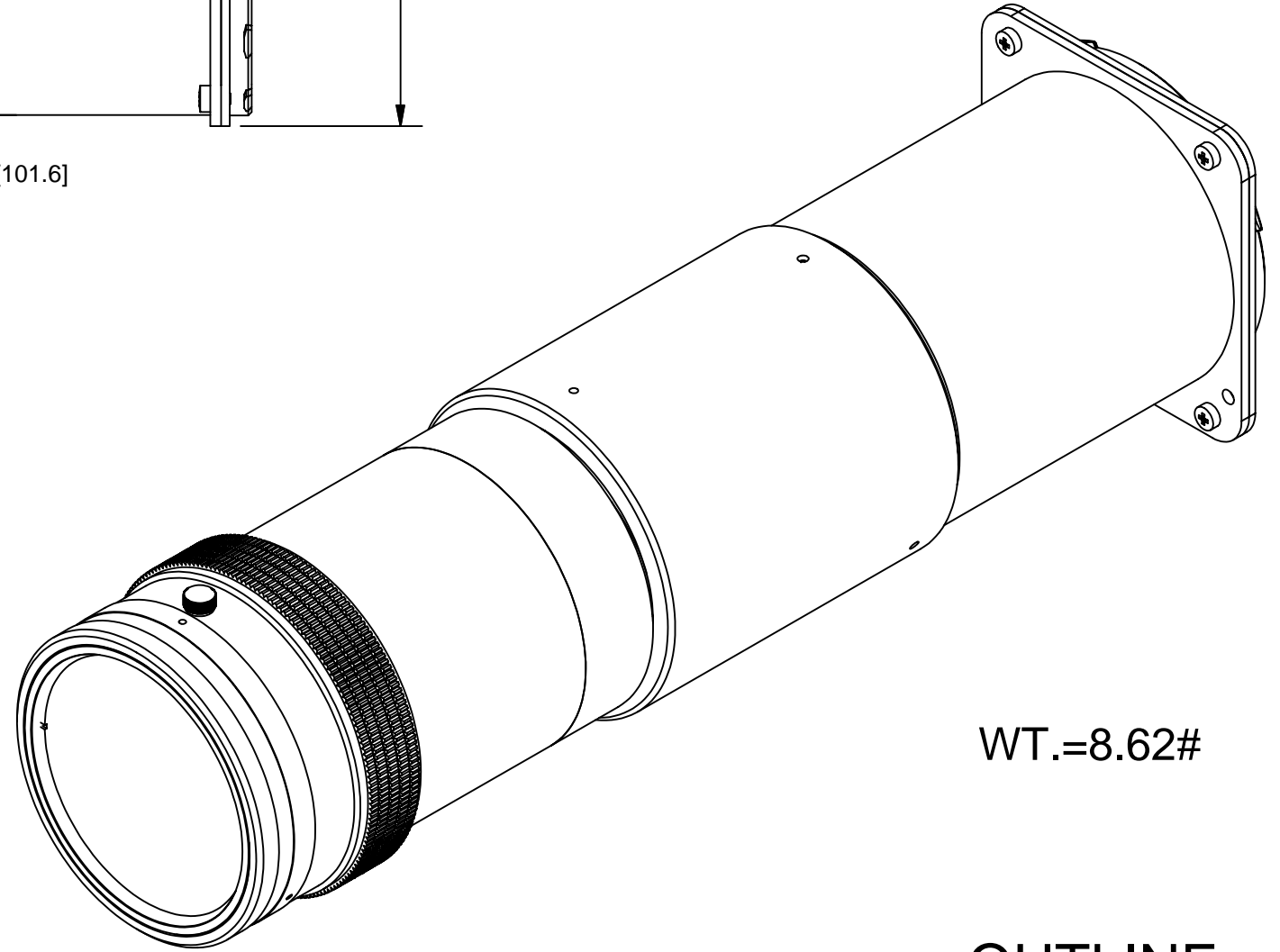
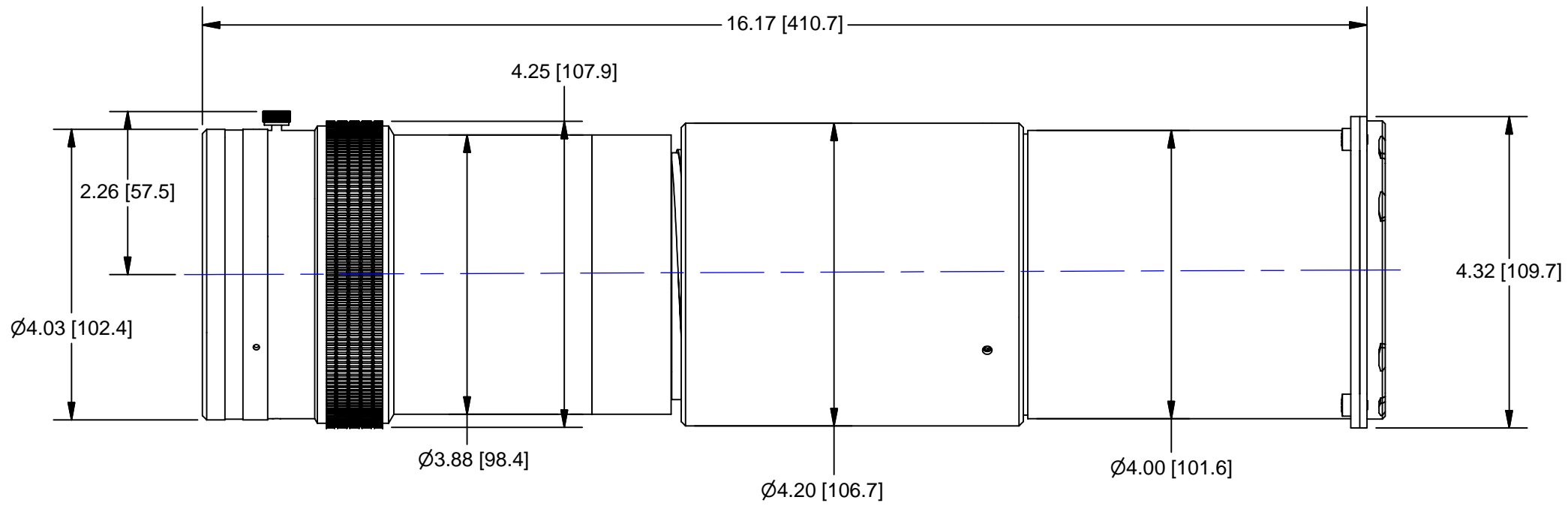

WT.=8.62#

OUTLINE

USED ON:

MATERIAL:

UNLESS OTHERWISE SPECIFIED DIMENSIONS ARE IN INCHES AND INCLUDE CHEMICALLY APPLIED OR PLATED FINISHES

TOLERANCES AS FOLLOWS
 DEC. .XXX ± .005
 DEC. .XX ± .010
 FRACT. ± 1/64
 ANGLES ± 30'
 CONCENTRICITY .003 TIR
 BREAK ALL SHARP EDGES .005 MIN. .010 MAX.
 MAX. SURF. ROUGHNESS: $\sqrt{32}$

CHAMFER ALL THREADS 30° TO ROOT DIAMETER

P/N SUFFIX DEFINITION
 -1 CONVERSION COATING
 -2 PAINTING
 -3 MARKING
 -R REWORK

SCALE: .5:1
 DR: BE
 CH: R. E. Podlena
 PROJECT #: E2005
 DATE DR: 7/21/2005
 DO NOT SCALE DRAWING

THE CONTENTS OF THIS DOCUMENT ARE PROPRIETARY TO NAVITAR, ITS USE IS AUTHORIZED ONLY FOR RESPONDING TO REQUEST FOR QUOTATION OR PERFORMANCE OF WORK FOR NAVITAR

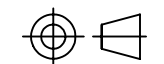
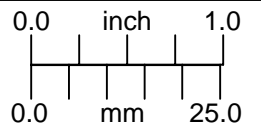

374MCZ183 283-472mm ZOOM LENS ASS'Y (EIKI LC-X6)

SIZE	1-16989	REV	A
B	SHEET 1 OF 1		