

VIDEOMATE 2300

*Video Slide Projector
Instruction Manual*

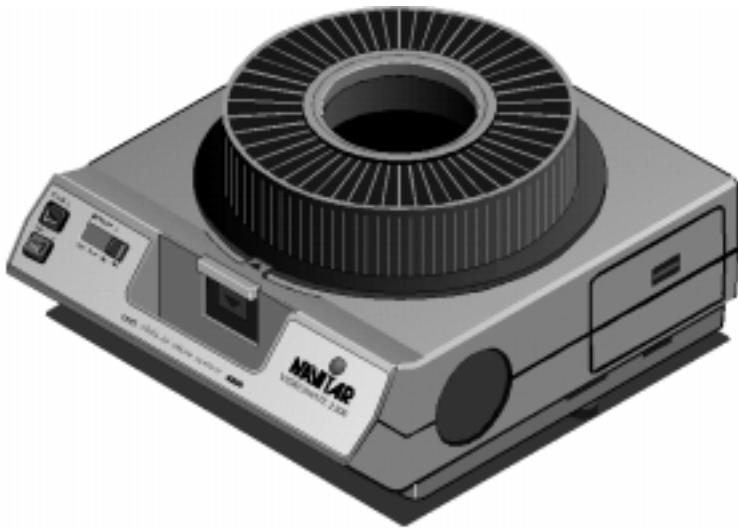

NAVITAR®
The World Leader in Image Quality

- 2 *Introduction to the VideoMate***
- 4 *System Diagrams***
- 6 *Safety Precautions***
- 7 *Quick Start***
- 8 *Installation & Operation***
- 10 *Slide Tray***
- 12 *Projection Lamps***
- 13 *Features and Functions***
- 17 *Troubleshooting***
- 18 *Specifications***
- 19 *Warranty***

Introduction to the VideoMate

VideoMate Slide-to-Video Systems

Today's sophisticated audiences expect high quality visual aids in the presentations they attend. Since a picture is "worth a thousand words," As they say, there is no better way to increase the effectiveness of a presentation than to pack it full of interesting visual images.

A Navitar VideoMate is an ideal presentation tool, because it enables you to easily integrate 35mm slides into presentations by converting them into video images which can be projected through a video projector or viewed on a TV monitor. VideoMates produce high resolution images with outstanding contrast and vivid color rendition, so slides can be shown as large projected video images without losing clarity or legibility. VideoMates are ideal for use in boardrooms, auditoriums and training rooms, or for AV rental and video production.

Description of the VideoMate 2300

The VideoMate 2300 is based on a state-of-the-art Kodak Ektagraphic slide projector. Integrated inside is a high resolution Interline Transfer CCD camera featuring Navitar's acclaimed precision optics. To increase on-screen resolution even further, the VideoMate 2300 can be used with a scan doubler.

The VideoMate 2300 outputs Y/C (S-Video) and composite signals. In addition, it has the ability to genlock into a video system.

The built-in motorized zoom lens allows the VideoMate 2300 to zoom in on slides for increased magnification or zoom out to view entire vertical slides.

Introduction to the VideoMate

Output to Video Equipment

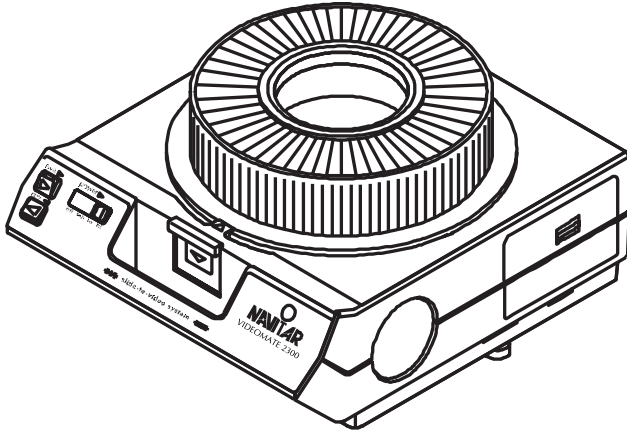

VideoMate
Slide-to-Video



Output to Video Equipment

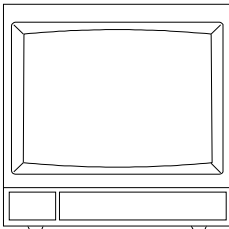

TV Monitor

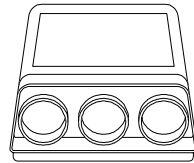

Video Projector

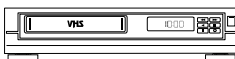

VCR

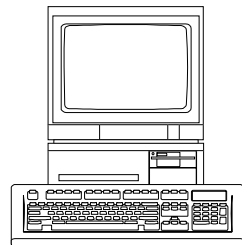

Computer

Top View

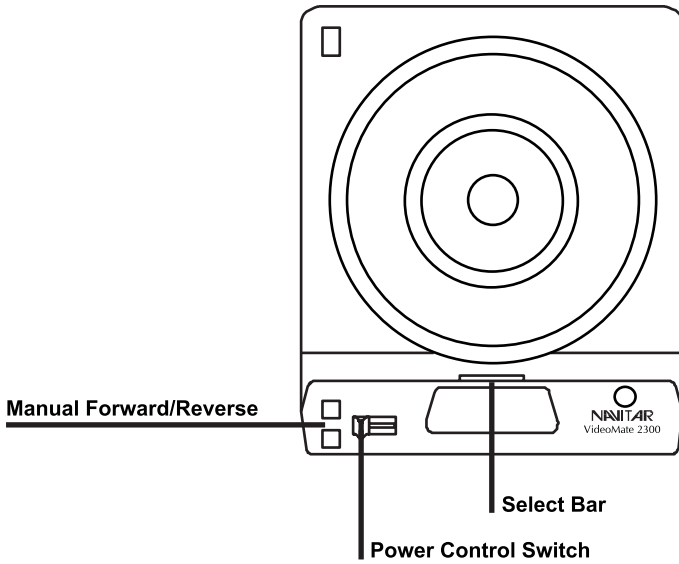

Side View

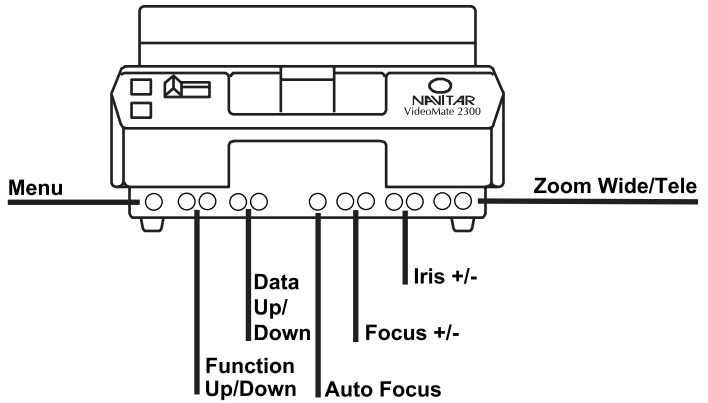

Front View

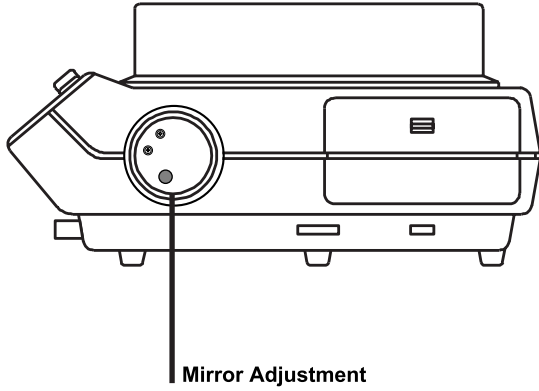

Rear View

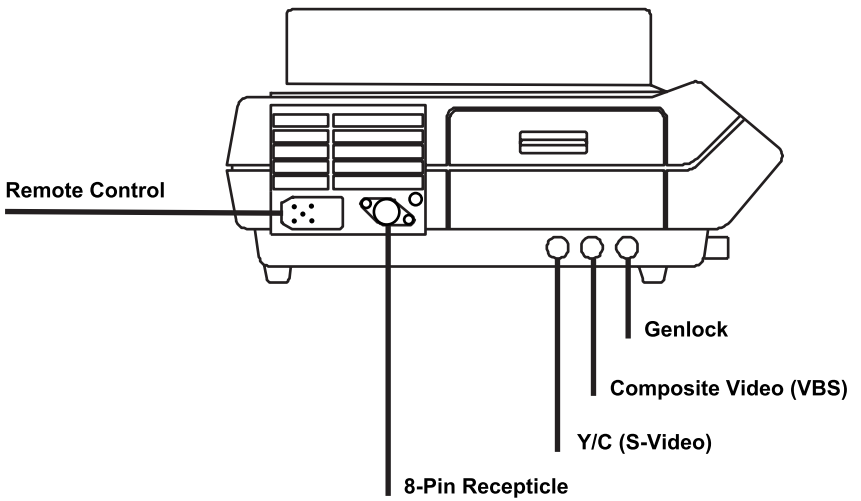

Safety Precautions

To prevent damage to the equipment and operating personnel, please observe the following precautions:

Use the correct voltage source as specified on the label.

Make sure that the voltage source contains a satisfactory path to ground.

Do not operate the unit where fluids can come into contact with the electrical components.

Maintain a six inch air space around all sides of the equipment to allow for proper ventilation.

When changing the bulb:

1. Disconnect the electrical supply.
2. Allow the unit to cool.
3. Use only ESJ or ESH lamps or the equivalent (82 volt, 85 watt). Higher wattage lamps will cause severe internal damage to the camera and electronics.

There are no user serviceable components (other than changing the lamp). Opening the unit will expose dangerous voltage levels and sensitive electronic components. A qualified technician should perform all repairs.

To protect the unit from damaging condensation and thermal shock, certain procedures must be followed.

1. In cold weather, always put the unit in a moisture proof container or enclosure before transporting.
2. Either keep the unit warm during transportation, or allow sufficient time for it to warm up at the destination. Keep the unit in the original moisture proof package while it warms up. (The goal is to prevent warm, moist air from striking the cold electronic and optical components, which will cause damaging condensation).

Warning



Never operate a cold projector to warm it up.

Quick Start

If you are familiar with both the operation of a 35mm slide projector and your video display, you may follow an abbreviated start-up procedure.

Before starting, review the precautions on page 6.

To “Quick Start” the VideoMate 2300, proceed as follows:

1. Unwind the cord under the base of the unit and plug it into a suitable power supply.
2. Connect your TV monitor to the composite video and/or Y/C (S-video) output connectors of the VideoMate.
3. Load the slide tray into the projector.
4. Turn the TV monitor on and set the VideoMate power switch to HIGH.
5. Advance to the first slide.
6. Adjust the zoom lens to achieve the correct image size.

Installation

Before starting, review the precautions on page 6.

To install the VideoMate 2300, proceed as follows:

1. Unwind the power cord under the base of the unit and plug it into a suitable power source.
2. Connect the cable to your peripheral equipment (TV monitor, video projector, etc.). The connection for composite video is BNC and is a 4-PIN MiniDin for Y/C (S-video).
3. Load the slide tray and “power-up” all equipment
4. Advance to the first slide.
5. The unit’s auto focus and auto iris functions will adjust to produce a clear image. (To turn the auto iris function ON/OFF, push the + and - buttons at the same time.)
6. Using the zoom lens controls located on the unit’s front control panel, zoom in or out to achieve the desired magnification.

Navitar provides an ultra wide zoom range, allowing you to zoom in on a horizontal slide for increased magnification, zoom out to see a whole vertical slide or zoom in to fill the screen with a vertical slide.

7. To genlock the VideoMate, a video switcher and one other video source are required. (See Genlock section page 15). A BNC connector is needed for the genlock input signal.
8. To shut the system down, hold the select bar down and rotate the slide tray to the zero index position. Set the power switch to OFF.
9. For instructions on setting up slide trays, changing lamps, etc., refer to the appropriate sections of this manual.

Adjustment of the Slide Position on the Monitor

Due to transportation, the image position might shift from the factory setting.

To correct this shift:

1. Remove two plugs as shown in the figure below.
2. Using a Phillips screw driver, rotate screw #1 to adjust the vertical position and screw #2 to adjust the horizontal position.
3. Replace the hole plugs.

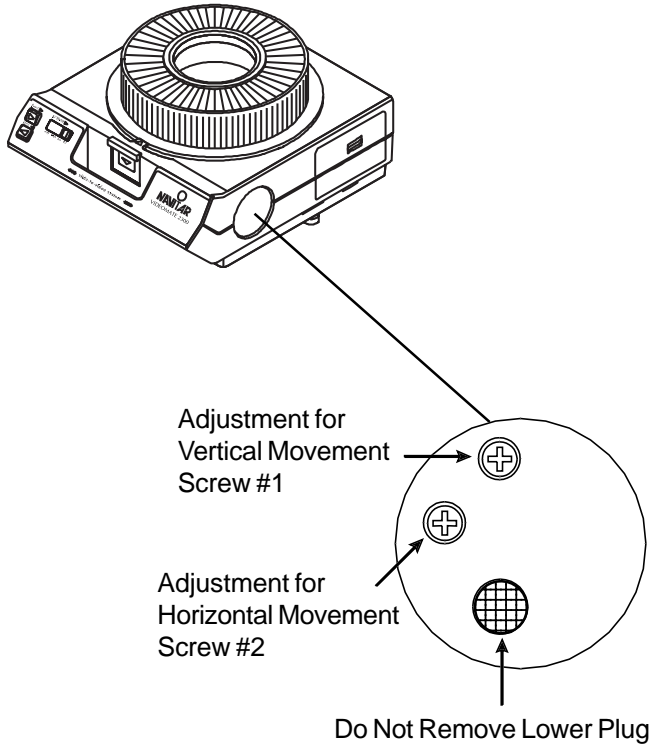

Understanding Which Video Input is Best for You

Composite Video

Standard video image quality, fine for showing pictures of objects on a TV monitor.

Y/C (also known as S-video and S-VHS)

Improved resolution that is less grainy due to the elimination of dot crawl. Better for presentation of text and graphic slides, since words are more defined.

Setting Up the Slide Tray

This system is designed to permit the use of previously prepared presentations without requiring a reorientation of slides.

For those setting up a new tray and/or presentation:

1. Arrange the slides in the order that they should appear in the presentation. Arrange them so that they are upright and reading correctly from left to right.
2. Rotate each slide to turn the image upside down (do not turn the slide over). Mark a sequential number in the upper right corner of each slide (this will be extremely useful if the slides ever become mixed). Use a felt tip marker, rather than labels that will be loosened by the heat.
3. Make sure that the bottom metal plate on the slide tray is indexed into the zero position (the plate will not rotate with respect to the top tray). Remove the top lock ring by rotating it counter clockwise.
4. Insert slide #1 into slot #1. The number written on the upper right corner of each slide should be at the top and facing the next higher numbered slot. Load all slides and replace and lock the top lock ring.

Installing the Slide Tray

1. Center the tray over the post on the projector.
2. Gently rotate the tray until the #0 slide slot is at the index mark and the tray will drop into position. If the tray does not drop into position, check to see that the lower metal plate is locked in the zero position (rotate until it locks).

Removing the Slide Tray

To remove the tray from the projector without loosening the slides:

1. Hold the selector bar down and rotate the tray back to the zero index position.
2. Lift the tray at the point opposite the index mark.

Slide Tray Jam

The tray may jam if a damaged slide is caught in the gate. To release the tray:

1. Turn the unit off.
2. Push the select bar down and the slide should come up.

If the tray is still jammed:

1. While holding the projector post release tab located at the center of the slide tray, grasp the tray on the side opposite the index mark and lift. When the tray is removed, the select bar will release the slide.
2. Invert the slide tray and rotate the bottom metal plate until it locks into the zero position. This will prevent the slides from falling out from the bottom of the slide tray.
3. Return the tray to an upright position and remove the lock ring. If the slide is undamaged, return it to its proper slot. Replace the lock ring and continue.

Lamps

The VideoMate will function with either of the 85 watt, 82 volt lamps listed below. One provides a higher color temperature, while the other exhibits a much longer life.

Warning



To prevent a severe “melt-down,” do not use 250-300 watt, 82 volt slide projector lamps.

Lamp#	Voltage	Watts	Life	Color Temp.
ESH	82	85	250 hr.	2950 K
ESJ*	82	85	40 hr.	3350 K

*Standard lamp supplied with VideoMate.

Replacing the Lamp

The entire illumination system is contained in a unit called a lamp module. This module is a drawer type configuration, which may be removed from the projector to change the lamp.

Unfortunately, it takes 5 to 10 minutes to change the lamp, because it must first be allowed to cool down. Therefore, if timing is critical, you should keep a spare lamp module on-hand in case a lamp burns out in the middle of a presentation. Replacing the module takes considerably less time than changing the lamp. Spare lamp modules can be purchased. Please call for price and availability.

To change the lamp:

1. If the unit has been running, switch the power to FAN and wait 5 to 10 minutes for it to cool down.
2. Turn the power switch to OFF.
3. Press down on the door latch of the lamp module and pull it slowly outward until the module clears the projector.
4. Unclasp the wire bail, which holds the lamp in place and push from underneath the lamp to slide the lamp out of the receptacle.
5. Reverse the procedure to insert the new lamp (make sure that the new lamp is properly seated).
6. Lock the new lamp into place with the wire bail.

8-Pin Receptacle The 8-pin receptacle provides access to the circuitry of the projector and allows for additional external control and programming capability. Functions include forward and reverse slide change, sensing of the zero tray position when the shutter is closed and electrical grounding. 8-contact or "DIN-type" 3 and 5 contact plugs may be used. 22.5 volts of isolated power is available.

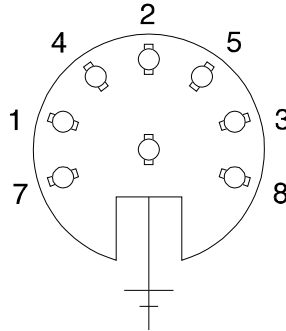

Warning



All circuits connected electrically to the projector through this receptacle must have a rating of no more than 30 V (rms) and must comply with Underwriters Laboratories, Inc. low voltage, limited-energy circuit requirements.

8-Pin Contact Data

1 and 3 (Zero Position Switch)

Connects to an internal single-pole, single-throw, normally open switch. Contacts are closed when the projector slide tray is at any position other than zero. These leads connect only to the switch terminals. Do not exceed a switching load of 1 A at 30 V ac.

4 and 5 (Shutter Switch)

Connects to an internal single-pole, single-throw normally closed switch. Contacts are open when a slide is in the projector gate and the shutter is open. These leads connect only to the switch terminals. Do not exceed a switching load of 1 A at 30 V ac.

7 and 8 (Low Voltage Supply)

For operating external equipment. The current is supplied by a secondary winding on the main motor, isolated from the line-voltage power, and is available whenever the main projector motor is running. Supply is 25.5 V, 500 mA (1/2 A) maximum. Contact number 8 is common (return) for the remote-control circuit. Contact number 7 is the “hot” lead and is fused with a slow-blowing fuse. Replacement requires disassembly of the projector by a qualified technician

6 and 8 (Forward Tray Cycle)

Connects to the forward tray-advance circuitry in the projector. These contacts are connected internally to the remote-accessory receptacle and an electrical connection made at either receptacle will result in a forward cycle.

2 and 8 (Reverse Tray Cycle)

Connects to the reverse tray-advance circuitry in the projector. These contacts are connected internally to the remote-accessory receptacle and an electrical connection made at either receptacle will result in a reverse cycle.

Shell (Plug Ground)

If a plug with a conducting shell is used, it is connected to the projector frame (chassis) through the special-application receptacle and to earth ground through the projector’s cable.

5-Pin EBY Connector for Remote Control

The EBY remote control connector is located in the rear of your projector. This 5-Pin connector controls zoom, slide forward and slide reverse via remote control.

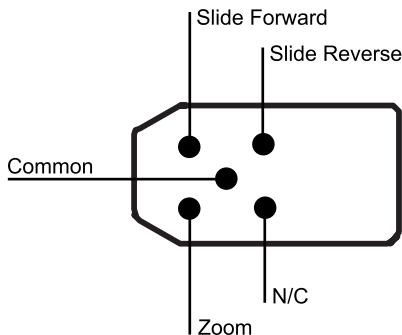

Genlock

The VideoMate 2300 can be genlocked into any video system. In order to utilize the genlock feature, a second video source, a video switcher box and the appropriate input/output cables are required. We also strongly recommend the use of a vector scope for the best possible results.

Genlock Adjustment

Once genlock is connected, access the menu and follow the step-by-step directions.

On-Screen Menu

→ MODE	● AUTO	INT
H PHASE	0	
SC PHASE	● 0	180
SC FINE	0	

When an external sync signal is input, the display mode changes from the factory set INT (internal sync) to AUTO (external sync).

Changing AUTO Settings

To select the item you want to adjust, move the arrow “→” on the left side of the screen up and down by pushing the FUNCTION UP, FUNCTION DOWN buttons. Once you choose an item, you can change the setting by pushing the DATA UP, DATA DOWN buttons.

Adjusting the Horizontal Phase

1. Set the arrow “→” to H PHASE by pushing the FUNCTION UP, FUNCTION DOWN buttons.
2. Adjust the horizontal phase by pushing the DATA UP, DATA DOWN buttons. The values range from -99 to 99, DATA UP will increase the setting towards 99 and DATA DOWN will decrease it towards -99.

Coarse Adjustment of the Sub Carrier Phase

1. Set the arrow “→” to SC 0/180 by pushing the FUNCTION UP, FUNCTION DOWN buttons.
2. Select either 0 or 180 by pushing the DATA UP, DATA DOWN buttons.

Adjusting the Sub Carrier Phase

1. Set the arrow "→" to SC PHASE by pushing the FUNCTION UP, FUNCTION DOWN buttons.
2. Adjust the sub carrier phase by pushing the DATA UP, DATA DOWN buttons. The values range from -99 to 99, DATA UP will increase the setting towards 99 and DATA DOWN will decrease it towards -99.

Y/C Genlock and Composite Video Genlock

The on-screen resolution of the Y/C (S-video) image is less grainy and appears sharper than the composite video image. Until now, video manufacturers only allowed the composite video signal to be genlocked with a video switcher system. The technology in the VideoMate 2300, however, now allows the higher quality Y/C image to be genlocked to a Y/C video switcher, thereby improving the on-screen picture quality. For standard applications you can genlock the composite video signal.

Genlock Diagram

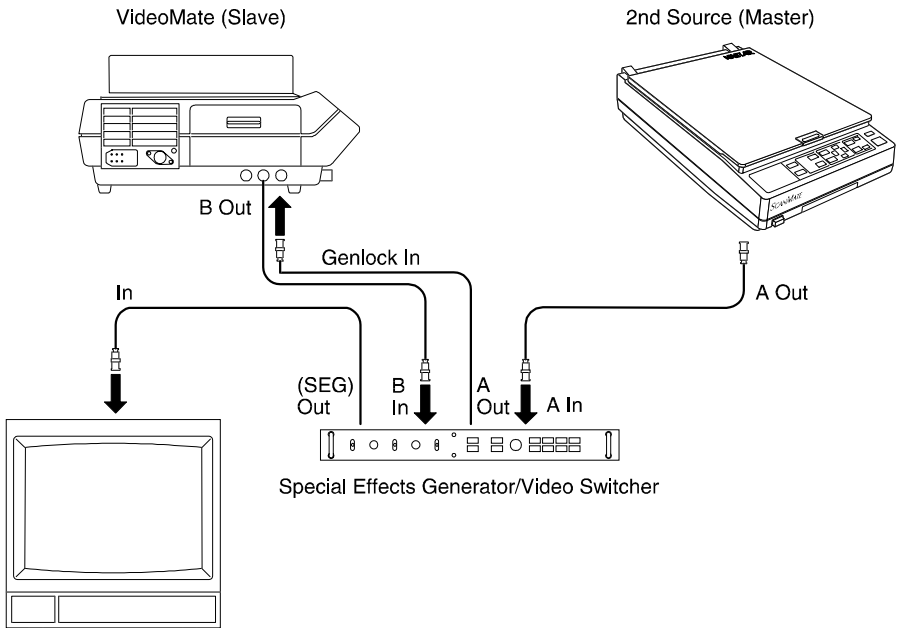

SYMPTOM	CAUSE/REMEDY
There is no image on-screen.	<p>Is all of the equipment "powered-up?" Check all of the electrical outlets and equipment power switches.</p> <p>Are the cables or connectors bad</p> <p>Is the lamp blown? Look in the film gate for a "light on condition."</p> <p>Is the gate shutter stuck in the closed position? Push down the select bar and release it.</p> <p>Turn the power switch to OFF, wait one minute and then try to restart.</p>
You are unable to recover the image after a brief interruption of power.	<p>Is the Lamp blown? The thermal shock of turning the unit on may have caused the lamp to blow.</p> <p>Is the gate shutter stuck in a closed position? Push down on the select bar to release it.</p>
The image is too dark or too light.	<p>Is the illumination level adequate? Set the iris (I) as required.</p> <p>Is the monitor adjusted correctly?</p>
The image is not sharp.	<p>Is the focus adjusted properly?</p> <p>Is the illumination level too high? Set the iris (I) as required.</p> <p>Is the monitor adjusted correctly?</p> <p>Are you using the correct grade of cables? They should be "grounded shield video" grade, 75 OHM.</p>
The image does not stabilize.	<p>Check the menu adjustment for genlock.</p>
The genlock does not operate properly.	<p>Are the cables going in and out of the video switcher connected properly?</p> <p>Are the fine and coarse phase adjustments correct?</p>

Camera

Pick-up Device	1/3" interline transfer CCD
Pixel Count	NTSC 768 (H) x 494 (V)
Signal System	NTSC standard
Horizontal Resolution	460 TV lines
Sensitivity	F1.8 (7 Lux), 3200K color temperature
Genlock	Yes, fine and coarse chroma and H-phase adjustment
S/N Ratio	48dB standard

Projector

Model Number	1-13401
Power Consumption	191 watts, 1.7 amps
Power	120 volts, 60Hz
Projector Lamp	82 volt, 85 watt GE ESJ
Lens	12X Motorized
Iris/Focus Controls	Motorized
Controls/Manual	On/off, forward/reverse, zoom in/out, focus & iris
Remote Operation	Remote controlled by contact closure using standard 5-pin connectors to control zoom and forward/reverse
Camera Connectors	BNC - Composite Video & genlock, 4-pin MiniDin - Y/C (S-Video)
Dimensions	Length 11.11 in. / 310 mm Width 12.93 in. / 328 mm Height 4.69 in. / 119 mm Weight 15 lbs. / 6.82 kg.
Video Cables (optional)	Model 8-11113, 12 foot, S-Video cable Model 1-11787, 12 foot Composite Video cable

Design and specifications are subject to change without notice.

5 Years Parts/ 5 Years Labor

This product is warranted to be free from defects in material and workmanship for a period of five years from the date of invoice to the original purchaser.

If during the warranty period the product is found to be defective, it will be repaired or replaced at the facilities of Navitar. However, Navitar reserves the right to refund the purchase price if the replacement or repair is not commercially practical or timely. Parts not manufactured by Navitar carry only the warranty of their manufacturer. Lamps and fuses carry no warranty.

This warranty does not cover damage caused in transit; damage caused by misuse, neglect or carelessness; or damage resulting from either improper servicing or modification by someone other than Navitar. Further, this warranty does not cover any routine maintenance work that is reasonably expected to be performed by the purchaser.

No responsibility is assumed for unsatisfactory operating performance due to environmental conditions such as humidity, dust, corrosive chemicals, deposition of oil or other foreign matter, spillage or other conditions beyond the control of Navitar.

For service, repair or return procedures under this warranty, contact your distributor, your local Navitar field officer or Navitar direct at (716) 359-4000 or (800) 828-6778 in the United States.

Except as stated herein, Navitar makes no other warranties, expressed or implied by law, whether of merchantability, fitness for a particular purpose or otherwise. Further, Navitar shall not, under any circumstances, be liable for incidental, consequential or other damages.

This warranty applies only to those original purchasers (non-dealers) returning the product warranty card within 30 days of purchase date. For purchasers who do not return the warranty card within 30 days, or for items sold to dealers for their own use or rental use, our standard 90 day parts and 1 year labor warranty will apply.

Ektagraphic and Kodak are both trademarks of the Eastman Kodak Company.

VideoMate and Navitar are both trademarks of Navitar, Inc.

NAVITAR®

NAVITAR, Inc.

200 Commerce Drive

Rochester, NY 14623 USA

(716) 359-4000 phone

(716) 359-4999 fax

<http://navitar.com/> internet

info@navitar.com email